

HAFCO WOODMASTER

WOOD BAND SAW OPERATION MANUAL



Models
BP-255, BP-310, BP-360

Edition No : WBS-001

Date of Issue : 08/2017

www.machineryhouse.com.au

MACHINE DETAILS**MACHINE**

WOOD BAND SAW

MODEL NO.**SERIAL NO.****DATE OF MANF.**

Distributed by

www.machineryhouse.com.auwww.machineryhouse.co.nz**NOTE:**

This manual is only for your reference. Owing to the continuous improvement of the machine, changes may be made at any time without obligation or notice. Please ensure the local voltage is the same as listed on the specification plate before operating this electric machine.

**NOTE:**

In order to see the type and model of the machine, please see the specification plate. Usually found on the back of the machine. See example (Fig.1)

A rectangular product specification plate with the HAFCO logo at the top. Below the logo, it says "PRODUCT SPECIFICATION". There are seven rows of labels followed by empty rectangular boxes for input: MODEL:, CAPACITY:, SER. NO:, MFG DATE:, WEIGHT:, VOLTS:, and MOTOR Kw:. At the bottom, it lists the website www.machineryhouse.com.au and "Made in China".

HAFCO	
PRODUCT SPECIFICATION	
MODEL:	<input type="text"/>
CAPACITY:	<input type="text"/>
SER. NO:	<input type="text"/>
MFG DATE:	<input type="text"/>
WEIGHT:	<input type="text"/>
VOLTS:	<input type="text"/>
MOTOR Kw:	<input type="text"/>
www.machineryhouse.com.au	
Made in China	

Fig.1

OPERATION MANUAL

C O N T E N T S :

1. GENERAL MACHINE INFORMATION	
1.1 Identification.....	4
1.2 Specifications.....	5
2. IMPORTANT SAFETY INFORMATION	
2.1 Safety Requirements.....	6
2.2 Safety For Band Saws.....	8
3. INSTALLATION	
3.1 Site Consideration.....	9
3.2 Electrical Installation.....	10
3.3 Unpacking.....	11
3.4 Installation.....	12
3.5 Test Run.....	14
4. ADJUSTMENTS	
4.1 Tilting Table.....	15
4.2 Blade Tracking.....	15
4.3 Tensioning the Blade.....	16
4.4 Adjusting Support Bearings.....	17
4.5 Blade Guide Adjustment.....	17
5. OPERATION	
5.1 Basic Controls.....	18
5.2 Blade Information.....	19
5.3 Changing The Blade.....	20
6. MAINTENANCE	
6.1 Troubleshooting.....	21
6.2 Wheel Alignment.....	22
Spare Parts.....	23
APPENDIX	
Risk Assessment Sheets.....	32

1.1 IDENTIFICATION

Fig. 1.1

1.2 SPECIFICATIONS

MODEL	BP-255	BP-310	BP-360
Throat Capacity (mm)	245	305	340
Wheel Diameter (Ø) (mm)	255	310	360
Height Capacity (mm)	152	165	225
Table Size (mm)	360 x 320	480 x 390	545 x 515
Table Tilt	0 - 45°	0 - 45°	0 - 45°
Frame Type	Steel	Steel	Steel
Blade Guide Type	Ball Bearing	Ball Bearing	Ball Bearing
Motor Power (kW / hp)	0.37 / 0.5	0.75 / 1	1.1 / 1.5
Cutting Speeds (m/min)	400 / 800	370 / 800	370 / 800
Voltage / Amperage (V / amp)	240 / 10	240 / 10	240 / 10
Blade Order Code (Suits)	W950A, W950B, W950F	W420A, W420B, W420F	W955A, W955B, W955F
Blade Size (L x W) (mm)	1826 x 3-12.5	2240 x 3-20mm	2560 x 3-25mm
Floor Space (W x D x H) (mm)	750 x 650 x 1430	830 x 700 x 1590	920 x 800 x 1710
Shipping Dimensions (L x W x H) (mm)	1020 x 450 x 380	1230 x 530 x 435	1350 x 575 x 440
Nett Weight (kg)	42	65	82

NOTE:

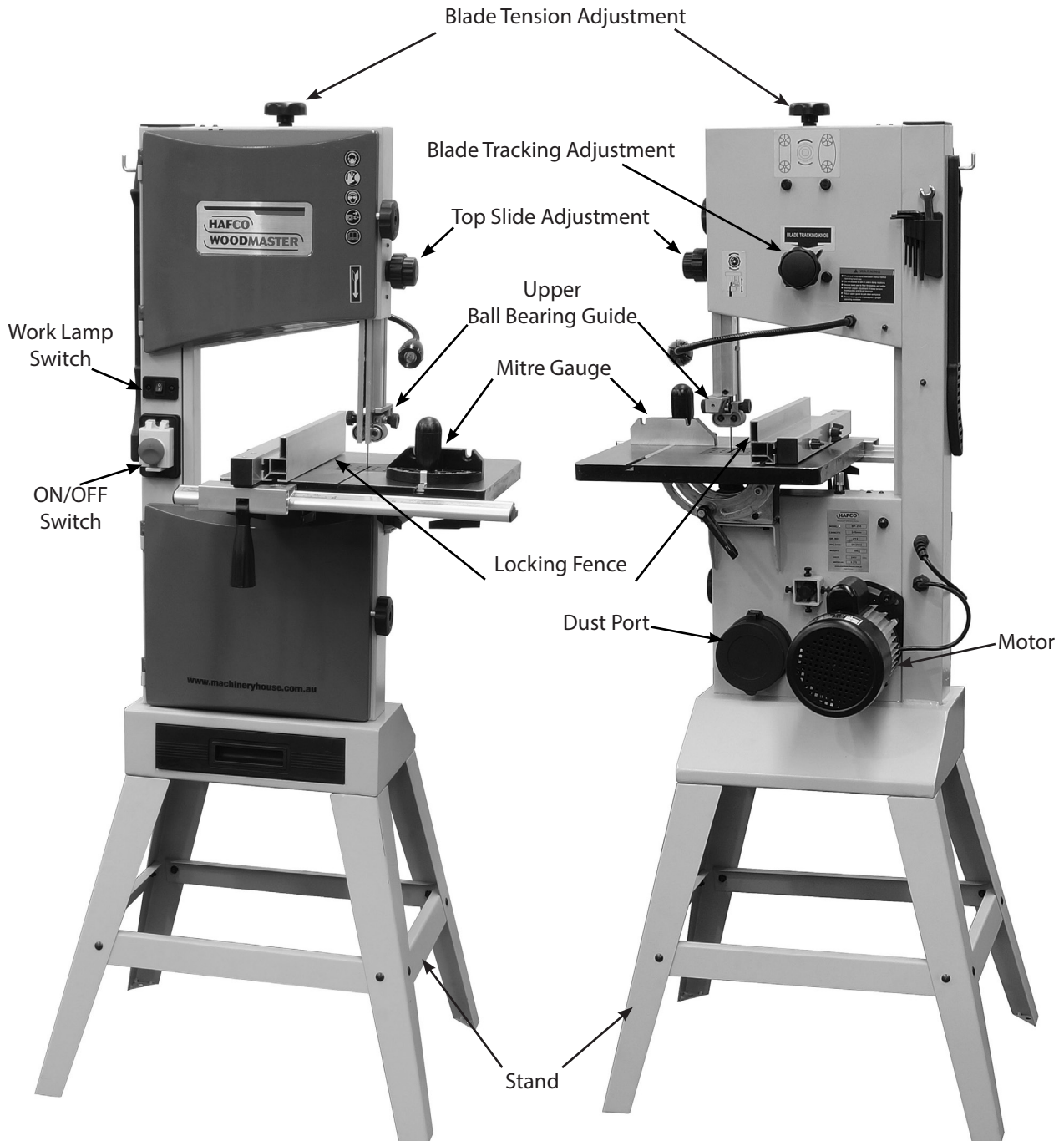
The specifications in this manual were current at time of publication, but because of our policy of continuous improvement, HAFCO reserves the right to change specifications at any time and without prior notice, without incurring obligations.

2. IMPORTANT SAFETY INFORMATION

2.1 SAFETY REQUIREMENTS

OWNER'S MANUAL. Read and understand this owner's manual BEFORE using machine.

TRAINED OPERATORS ONLY. Untrained operators have a higher risk of being hurt or killed. Only allow trained and supervised people to use this machine. When machine is not being used, disconnect the power, by removing the power plug to disable the machine and prevent unauthorized use, especially when around children.

DANGEROUS ENVIRONMENTS. Do not use machinery in areas that are wet, cluttered, or have poor lighting. Operating machinery in these areas greatly increases the risk of accidents and injury.

MENTAL ALERTNESS REQUIRED. Full mental alertness is required for the safe operation of machinery. Never operate under the influence of drugs or alcohol, when tired, or when distracted.

WEARING PROPER APPAREL. Do not wear clothing, apparel or jewelry that can become entangled in moving parts. Always tie back or cover long hair. Wear non-slip footwear to avoid accidental slips, which could cause loss of workpiece control.

HAZARDOUS DUST. Dust created while using the machinery may cause cancer, birth defects, or long-term respiratory damage. Be aware of dust hazards associated with each workpiece material, and always wear an approved respirator to reduce your risk.

HEARING PROTECTION. Always wear hearing protection when operating or near loud machinery. Extended exposure to this noise can cause permanent hearing loss.

ELECTRICAL EQUIPMENT INJURY RISKS. You can be shocked, burned, or killed by touching live electrical components or improperly grounded machinery. To reduce this risk, only allow qualified electrical personnel to do electrical installation or repair work, and always disconnect power before accessing or exposing electrical equipment.

DISCONNECT POWER FIRST. Always disconnect the machine from power supply BEFORE making adjustments, changing tooling, or servicing machine. This prevents an injury risk from unintended startup or contact with live electrical components.

EYE PROTECTION. Always wear approved safety glasses or a face shield when operating or observing machinery to reduce the risk of eye injury or blindness from flying particles. Everyday eyeglasses are NOT approved safety glasses.

REMOVE ADJUSTING TOOLS. Tools left on the machinery can become dangerous projectiles upon startup. Never leave keys, wrenches, or any other tools on machine. Always verify removal before starting!

USE CORRECT TOOL FOR THE JOB. Only use this tool for its intended purpose—do not force it or an attachment to do a job for which it was not designed. Never make any unapproved modifications—modifying the tool or using it differently than intended may result in malfunction or mechanical failure that can lead to personal injury or death!

NEVER STAND ON MACHINE. Serious injury may occur if machine is tipped or if the cutting tool is unintentionally contacted.

2.1 SAFETY PRECAUTIONS CONT.



AWKWARD POSITIONS. Keep proper footing and balance at all times when operating machine. Do not overreach! Avoid awkward hand positions that make the work-piece control difficult or increase the risk of accidental injury.

CHILDREN & BYSTANDERS. Keep children and bystanders at a safe distance from the work area. Stop using machine if they become a distraction.

GUARDS & COVERS. Guards and covers reduce accidental contact with moving parts or flying debris. Make sure they are properly installed, undamaged, and working correctly.

FORCING MACHINERY. Do not force the machine. It will do the job safer and better at the rate for which it was designed.

MAINTAIN POWER CORDS. When disconnecting the cord-connected machines from power, grab and pull the plug—NOT the cord. Pulling the cord may damage the wires inside. Do not handle the cord or plug with wet hands. Avoid cord damage by keeping it away from heated surfaces, high traffic areas, harsh chemicals, and wet or damp locations.

STABLE MACHINE. Unexpected movement during operation greatly increases risk of injury or loss of control. Before starting, verify machine is stable and mobile base (if used) is locked.

USE RECOMMENDED ACCESSORIES. Consult this owner's manual or the manufacturer for recommended accessories. Using improper accessories will increase the risk of serious injury.

UNATTENDED OPERATION. To reduce the risk of accidental injury, turn machine OFF and ensure all moving parts completely stop before walking away. Never leave machine running while unattended.

MAINTAIN WITH CARE. Follow all maintenance instructions and lubrication schedules to keep machine in good working condition. A machine that is improperly maintained could malfunction, leading to serious personal injury or death.

CHECK DAMAGED PARTS. Regularly inspect machine for any condition that may affect safe operation. Immediately repair or replace damaged or mis-adjusted parts before operating the machine.

2.2 SAFETY FOR BAND SAWS

BLADE CONDITION. Do not operate with dull, cracked or badly worn blade. Dull blades require more effort to perform the cut and increase the risk of kickback. Inspect blades for cracks and missing teeth before each use.

HAND PLACEMENT. Never position fingers or hands in line with the blade. If the workpiece or your hands slip, serious personal injury could occur.

WORKPIECE MATERIAL. This machine is intended for cutting natural and man-made wood products, and laminate covered wood products. This machine is NOT designed to cut metal, glass, stone, tile, etc.

BLADE REPLACEMENT. To avoid mishaps that could result in operator injury, make sure the blade teeth face down toward the table and the blade is properly tensioned and tracked before operating.

BLADE SPEED. Moving the workpiece against a blade that is not at full speed could cause kick-back. Always allow the blade to come to full speed before starting the cut.

GUARDS. The blade guard protects the operator from the moving band saw blade. ONLY operate this band-saw with the blade guard installed.

CUTTING TECHNIQUES. Plan your operation so the blade always cuts to the outside of the workpiece. DO NOT back the workpiece away from the blade while the band saw is running, which could cause kickback and personal injuries. If you need to back the workpiece out, turn the band saw OFF and wait for the blade to come to a complete stop. DO NOT twist or put excessive stress on the blade that could damage it.

LEAVING WORK AREA. Never leave a machine running unattended. Allow the band saw to come to a complete stop and remove the plug from the power point to disable the machine before you leave it unattended.

FEED RATE. To avoid the risk of the workpiece slipping and causing operator injury, always feed stock evenly and smoothly. DO NOT force or twist the blade while cutting, especially when sawing small curves.

SMALL WORKPIECE HANDLING. Always support/feed the workpiece with push sticks, jig, vise, or some type of clamping fixture. If your hands slip during a cut while holding small workpieces with your fingers, amputation or laceration injuries could occur.

BLADE CONTROL. To avoid serious personal injury, DO NOT attempt to stop or slow the blade with your hand or the workpiece. Allow the blade to stop on its own.

3. INSTALLATION

3.1 SITE CONSIDERATIONS

Weight Load

Check the Machine Specification plate mounted on the rear of the machine for the weight of the machine. Make sure that the surface, the machine is placed on, will bear the weight of the machine and any additional equipment that may be installed. This should include the heaviest workpiece that could be used, when assessing the weight of the machine

Space Allocation

Consider the largest size of workpiece that will be processed through the machine and provide enough space around the machine to adequately handle the largest workpiece or any accessory that may be used. With permanent installations, leave enough space around the machine to open or remove doors/covers as required by the maintenance and for service. See footprint below (Fig.3.1)

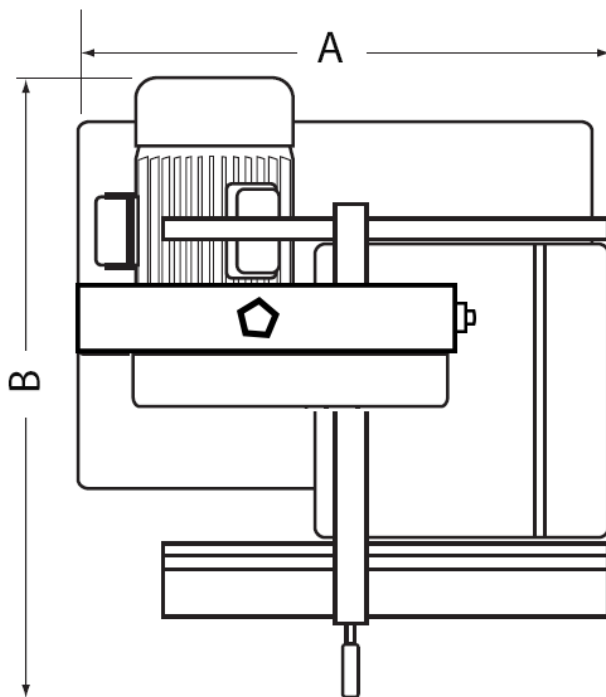

Model	A	B
BP-255	750	650
BP-310	830	700
BP-360	920	800

Fig. 3.1

Environment

The physical environment where the machine is operated is important for safe operation and longevity of the machine components. For best results, operate this machine in a dry environment that is free from excessive moisture, hazardous chemicals, airborne abrasives, or extreme conditions. Extreme conditions for this type of machinery are generally those that are outside a temperature range of 5°– 40°C. The environment should not be subject to vibration, shocks, or bumps.

3.2 ELECTRICAL INSTALLATION

Place this machine near an existing power source. Make sure all power cords are protected from traffic, material handling, moisture, chemicals, or other hazards. Make sure there is access to a means of disconnecting the power source. The electrical circuit must meet the requirements for 240V. To minimize the risk of electrocution, fire, or equipment damage, installation work and electrical wiring **MUST** be done by an electrician or qualified service personnel.

Note ! The use of an extension cord is not recommended as it may decrease the life of electrical components on your machine. **NOTE:** Hafco/Woodmaster advise that extension leads should not be used permanently, but recommend that the plug be placed directly in to a wall socket.

Electrical Requirements

Nominal Voltage.....	240V
Cycle.....	50 Hz
Phase.....	Single-Phase
Power Supply Circuit.....	10 Amps
Full Load Current.....	3.3 Amps

(Full load current rating is also on the specification plate on the motor.)



Full-Load Current Rating

The full-load current rating is the amperage a machine draws at when running at 100% of the output power. Where machines have more than one motor, the full load current is the amperage drawn by the largest motor or a total of all the motors and electrical devices that might operate at one time during normal operations.

Full-Load Current Rating at 240V..... 2.6 - 3.6 Amps

It should be noted that the full-load current is not the maximum amount of amps that the machine will draw. If the machine is overloaded, it will draw additional amps beyond the full-load rating and if the machine is overloaded for a long period of time, damage, overheating, or fire may be caused to the motor and circuitry.

This is especially true if connected to an undersized circuit or a long extension lead. To reduce the risk of these hazards, avoid overloading the machine during operation and make sure it is connected to a power supply circuit that meets the requirements.

3.3 UNPACKING

Read and understand all the assembly instructions before attempting assembly. Failure to comply may cause serious injury. Remove all contents from shipping carton. Do not discard carton or packing material until the band saw is assembled and running satisfactorily. Compare the contents of carton against list of parts below. The number identification in the list corresponds to items shown in Figures 3.2. This is your key for identifying the parts used throughout the Assembly section for easy reference. Remove the protective coating that is applied to the table with a household grease and spot remover.

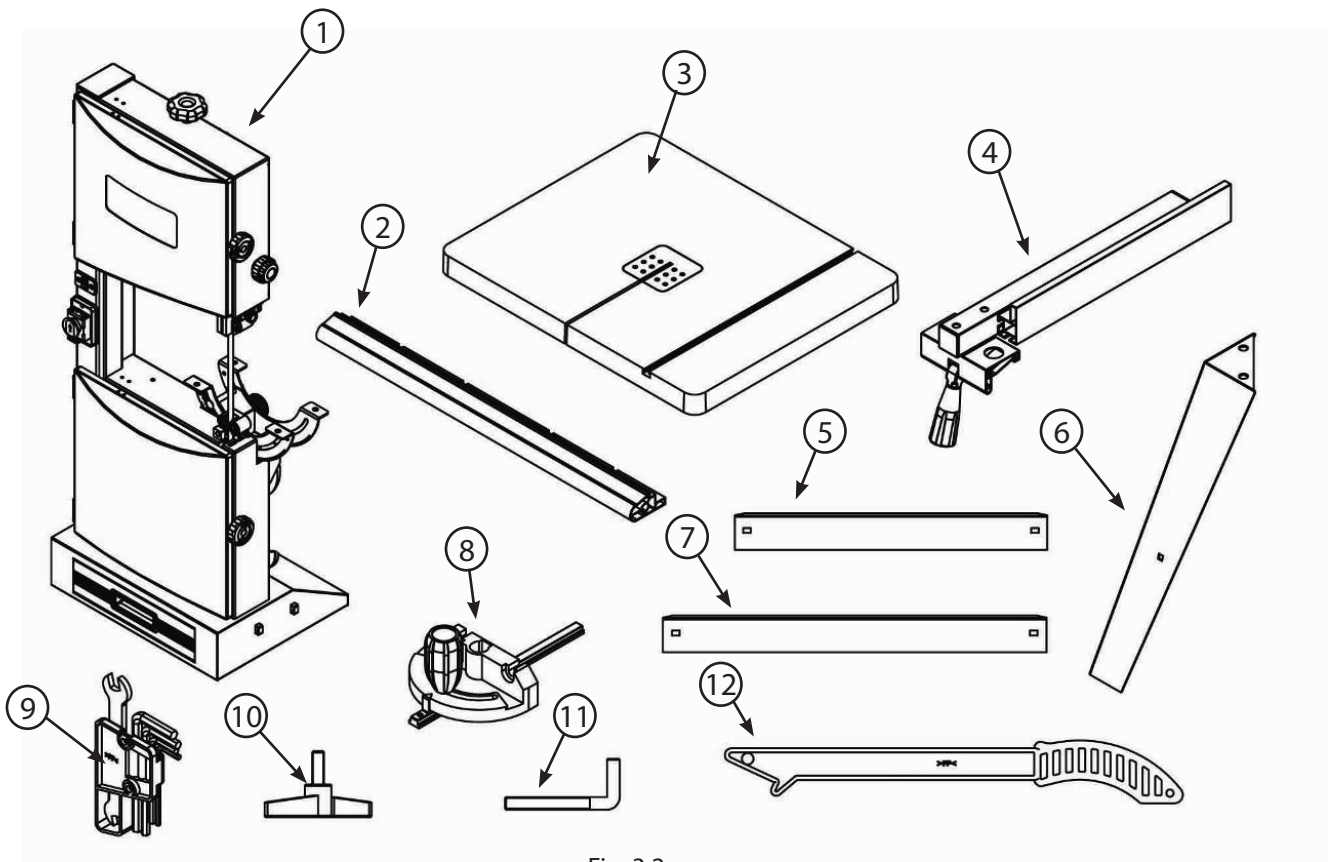

Fig. 3.2

1. Band saw	1pc	11. Hook with hex nut	1pc
2. Guide rail	1pc	12. Push stick	1pc
3. Table with insert	1pc	13. Hardware bag (not shown)	
4. Rip fence	1pc	M6X10 socket head bolts	8pcs
5. Short brace	2pcs	M6X10 hex bolts	4pcs
6. Leg	4pcs	6mm flat washers	12pcs
7. Long brace	2pcs	M6X12 carriage bolts	8pcs
8. Mitre gauge	1pc	6mm flat washers	8pcs
9. Accessory tools assembly	1pc	M6 hex nut	8pcs
10. Knob	4pcs	M4X10 socket head bolts	2pcs

3.4 INSTALLATION

1. Stand Assembly

- ❑ Put down the machine on a timber (Fig. 3.3)
- ❑ Attach the legs to band saw by using M6X10 socket head bolts and 6mm flat washers
- ❑ Fix short braces and long braces to legs by using M6x12 bolts, 6mm flat washers and M6 hex nut. Do not tighten the nut at this time.
- ❑ Stand the band saw on a level ground, then tighten all bolts and nuts. (Fig. 3.4)

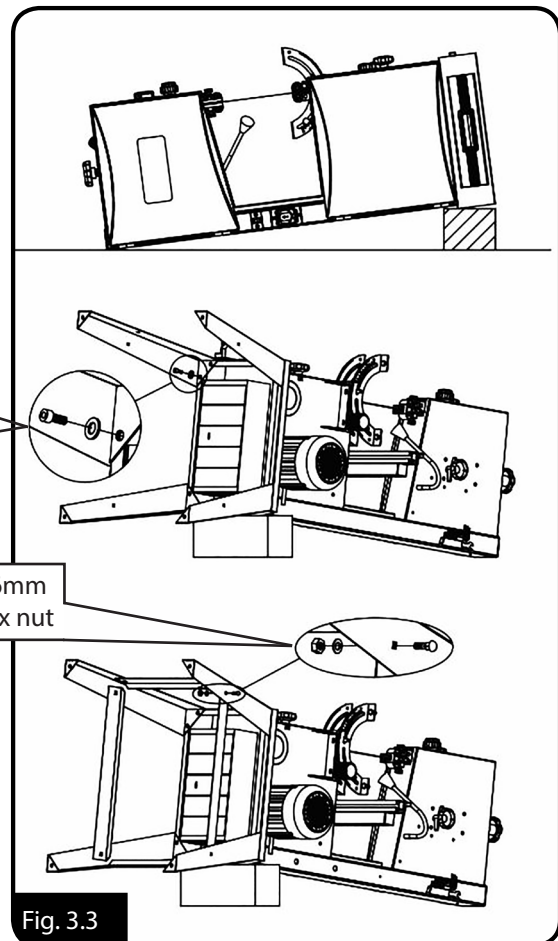
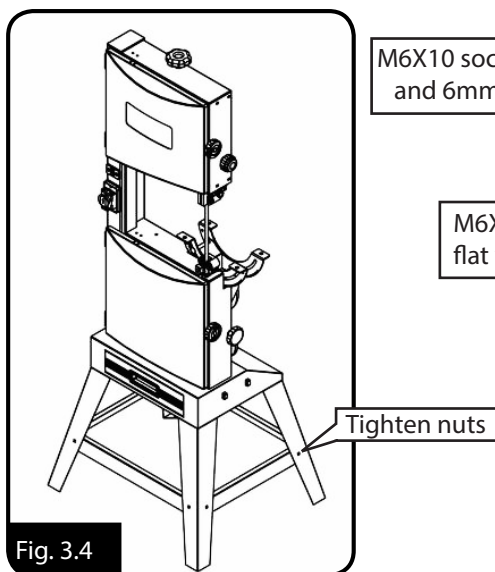

2. Assembling Table

After attaching the stand, mount the table on the band saw, using the M6X10 hex head bolts and 6mm flat washers.

Make sure the saw blade is in the centre of table insert slot. (Fig. 3.5)

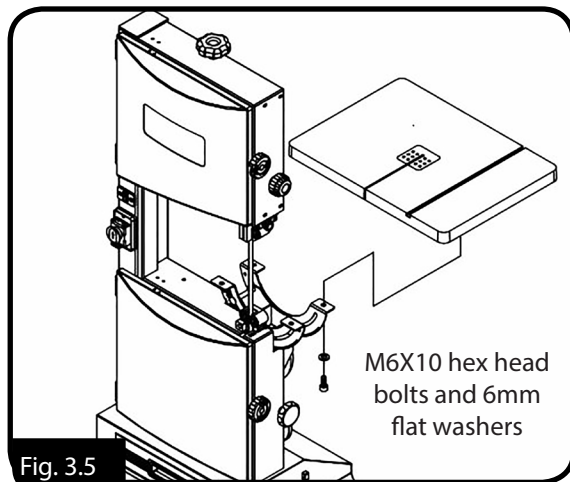

3. Installing the Guide Rail.

Secure the guide rail with the four knobs to the table. (Fig. 3.6)

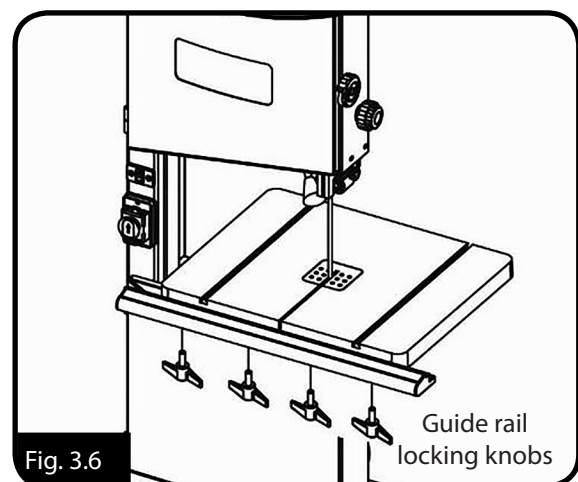

4. Installing The Accessory Tools:

Attach the tool set to the back of the frame by using M4X10 socket head bolts. (Fig.3.7)
Secure the hook with hex nut to the end of the frame.

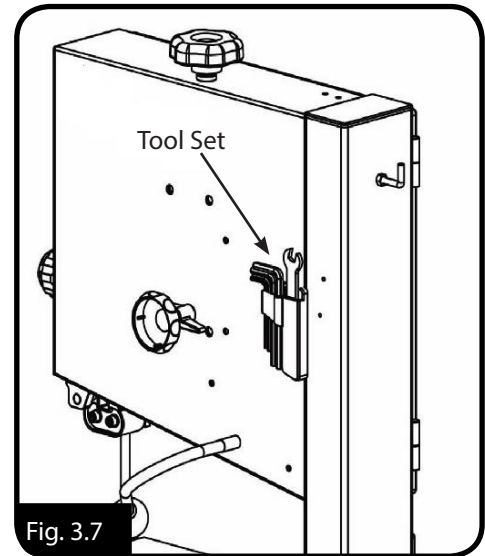

Fig. 3.7

5. Installing The Rip Fence:

Place the rip fence onto the table, and secure it to the guide rail.
Place the push stick onto the hook on the back of the machine. (Fig.3.8)

NOTE: Get into the habit of always replacing the push stick on the hook after use

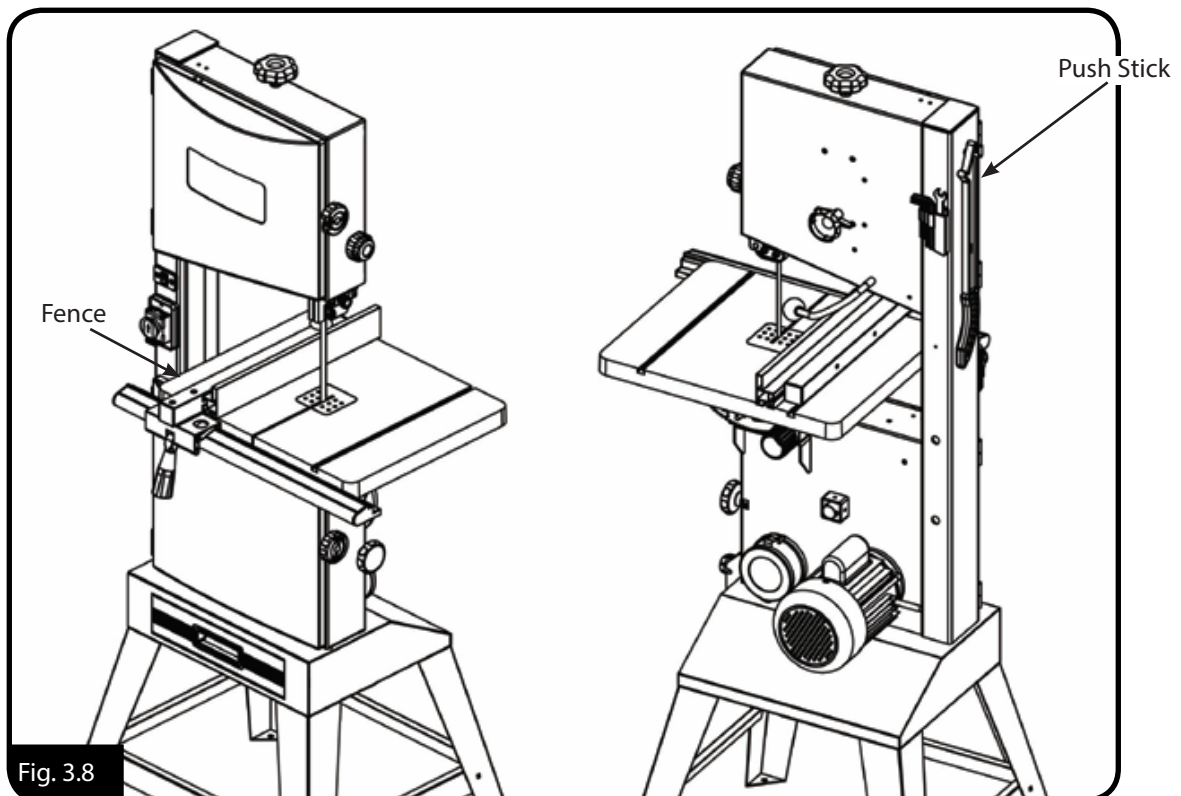

Fig. 3.8

3.5 TEST RUN

Once the assembly is complete, test run your machine to make sure it runs properly. If, during the test run, you cannot easily locate the source of an unusual noise or vibration, stop the machine immediately, then review the Troubleshooting section on Page 21. If you still cannot remedy a problem, contact your distributor. The test procedure is as follows.

1. Make sure you have read the safety instructions at the beginning of the manual and that the machine is set up properly, including Blade Tracking on Page 15
2. Make sure all tools and objects used during setup have been cleared away from the machine.
3. Connect the machine to the power source.
4. Turn the machine ON.
5. Listen and watch for abnormal noises or actions. The machine should run smoothly with little or no vibration or rubbing noises. — Strange or unusual noises must be investigated and corrected before operating the machine further. Always disconnect the machine from power when investigating or correcting potential problems.
6. Turn the machine OFF

TABLE STOP CALIBRATION

After tilting the table the adjustable positive stop allows the table to be reset 90° to the blade.

To set the positive stop:

1. DISCONNECT BAND SAW FROM POWER!
2. For the BP-255, adjust the blade tension see Page 16 (For BP-310, BP-360 adjust until the mark on the blade tension scale matches the size of the installed blade.)
3. Loosen the hex nut that locks the positive stop bolt in place and loosen the table tilt hand knobs.
4. Raise the guide post and place a machinist's square on the table next to the side of the blade, as illustrated in Fig. 3.9. Adjust the table square with the blade, then secure with the table tilt knobs.
5. Adjust the positive stop bolt to the table. (Fig. 3.10)
6. Secure the positive stop bolt by tightening the hex nut against the trunnion bracket.
7. Check the adjustment for accuracy once you have tightened the hex nut.

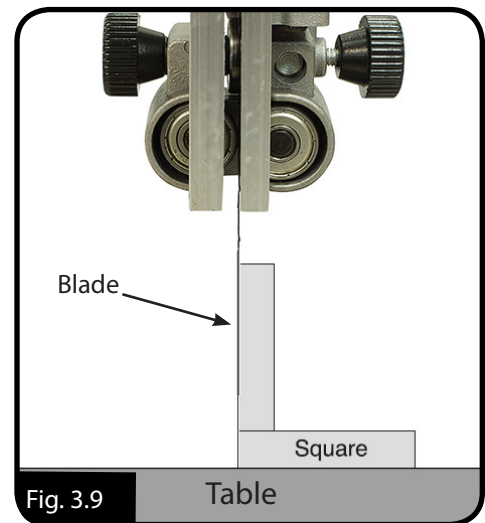

Fig. 3.9

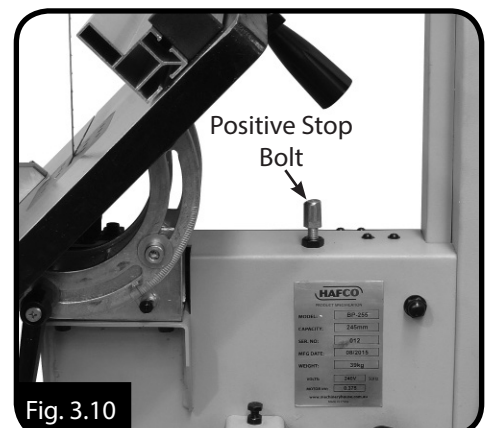

Fig. 3.10

4. ADJUSTMENTS

WARNING: Always be sure that the machine is switched off and unplugged before any adjustment is commenced.

4.1 TILTING TABLE

Loosen the locking handle and adjust the table to the desired angle.

Use the angle indicator scale to find the desired angle. The scale is only used as a guide. For very accurate angle use a protractor against the blade. Re-tighten the locking handle to secure the table.

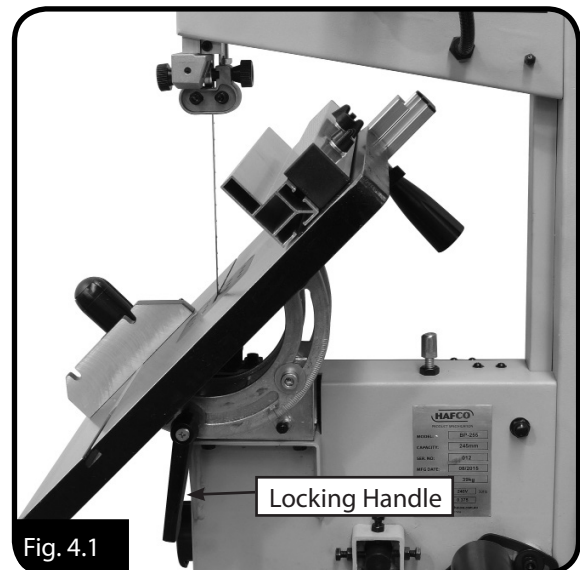

Fig. 4.1

4.2 BLADE TRACKING

If the saw blade does not run in the center of the rubber tyre, the tracking needs to be corrected by adjusting the tilt of the upper band saw wheel. To adjust the tracking open the upper and lower covers.

Loosen the tracking lock lever, (Fig. 4.3) manually rotate the upper wheel, taking care not to touch the blade.

Turn adjusting knob clockwise or anticlockwise until the saw blade tracks centered on the rubber tyre. After adjusting, re-tighten the tracking lock lever and close the cover.

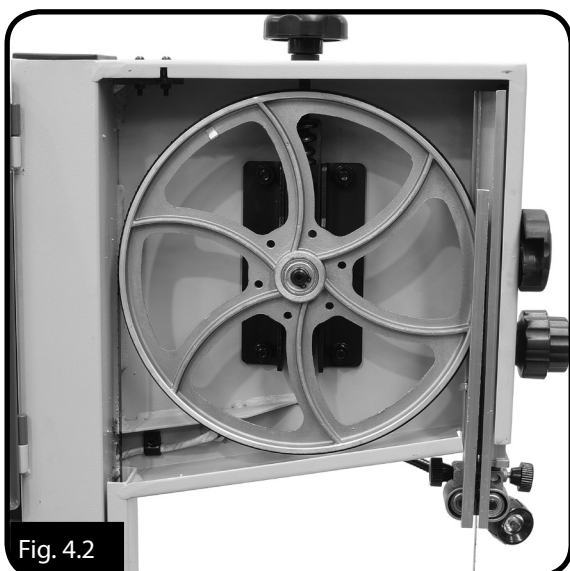

Fig. 4.2

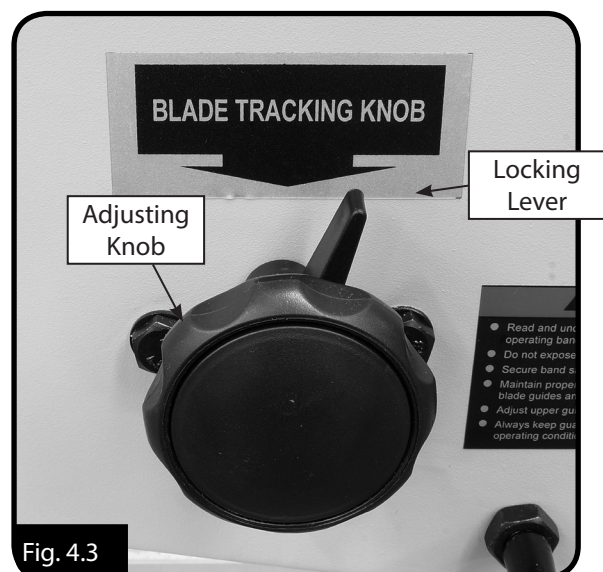

Fig. 4.3

4.3 TENSIONING THE BLADE.

A properly tensioned blade is essential for making accurate cuts and is necessary before making other band saw adjustments.

1. Raise the upper blade guide assembly as high as it will go, and adjust the upper and lower guide blocks approximately 0.5mm away from the blade. (Fig.4.4 & Fig.4.5)
2. Adjust the blade tension knob. Turning the setting knob clockwise will increase the blade tension and turning the setting knob counter-clockwise reduces the blade tension. (Fig.4.6)

NOTE: This procedure will not work if the guide blocks have any contact with the blade.



Fig. 4.4

3. Check the tension by pushing with a finger against the side blade, halfway between table and upper guide, (the blade should flex not more than 2mm) (Fig.4.7)
4. Turn the band saw ON.
5. Very slowly release the tension one quarter of a turn at a time. When you see the band saw blade start to flutter, stop decreasing the tension.
6. Now, slowly increase the tension until the blade stops fluttering, then tighten the tension another quarter of a turn.

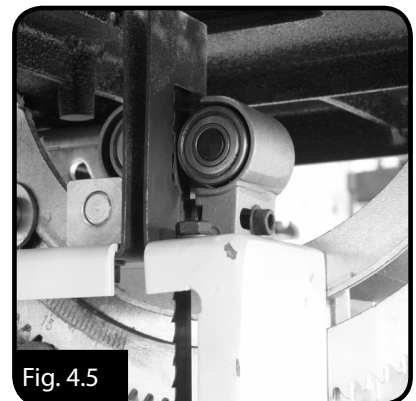

Fig. 4.5

WARNING: Too much tension can cause the band saw blade to break. Too little tension can cause the driven band saw wheel to slip and the saw blade to stop.

BLADE TENSION INDICATOR (BP-310 & BP-360)

On the BP-310 and BP-360 the tension should be checked by viewing the blade tension indicator. The scale indicates the correct adjustment of the blade in relation to the width of the band saw blade. (Fig. 4.8)



Fig. 4.6



Fig. 4.7

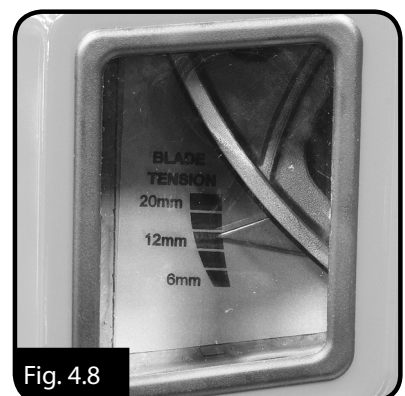

Fig. 4.8

4.4 ADJUSTING SUPPORT BEARINGS

The support bearings are positioned behind the blade for support during cutting operations. Proper adjustment of the support bearings is an important part of making accurate cuts. The procedure is as follows.

1. Make sure that the blade is tracking properly and that it is correctly tensioned.
2. **DISCONNECT BAND SAW FROM POWER!**
3. Familiarize yourself with the support bearing controls shown in Fig. 4.9
- A. Locks the bearing support roller in place after it has been moved back or forward.
- B. Locks the complete Blade Guide assembly. When unlocked the whole assembly can be moved forward or back when out of adjustment.
4. Loosen the thumbscrew on the support bearing adjustment shaft. (A in Fig.4.9)
5. Adjust the support bearing 0.5mm away from the back of the blade, as illustrated in Fig. 4.10
6. Repeat Steps 4–6 for the lower support bearings.

4.5 BLADE GUIDE ADJUSTMENTS

The blade guides consist of an upper and lower set of ball bearings that provide side-to-side support to help keep the blade straight while cutting. The blade guides are designed to be adjusted side-to-side.

1. Make sure that the blade is tracking properly and that it is correctly tensioned.
2. **DISCONNECT BAND SAW FROM POWER!**
3. Familiarize yourself with the blade guide controls shown in Fig. 4.8.
- C. The Socket head cap screws lock the side rollers in place after they have been moved towards or away from the side of the blade.
4. Undo the socket head cap screw of the blade guide bearings.
5. Using a feeler gauge laterally position the bearings 0.1mm away from the blade. (C in Fig. 4.8)
6. Tighten the cap screw to lock the blade guide bearings in position.

Repeat Step 4-6 for the lower guides.

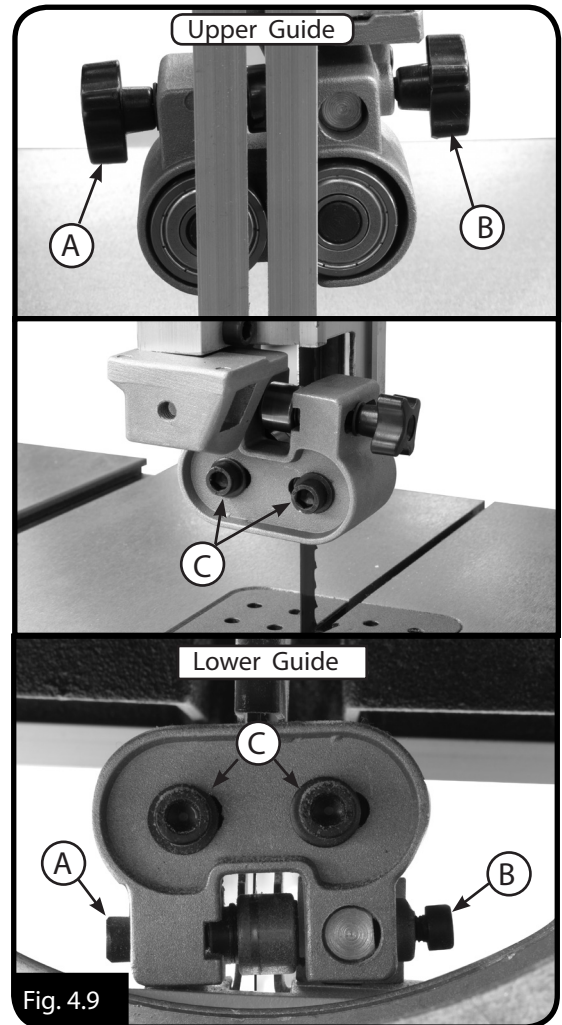

Fig. 4.9

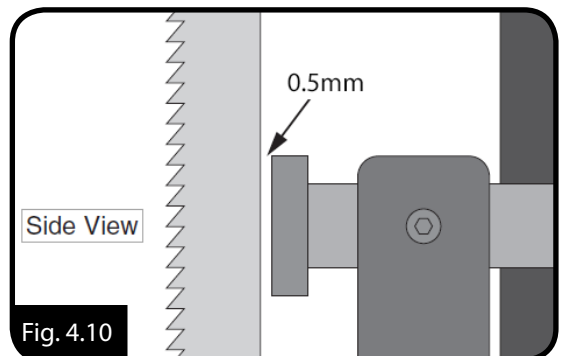

Fig. 4.10

5. OPERATION

5.1 Basic Controls

Use the descriptions below to become familiar with the basic controls of your machine.

Blade Tension Knob: Adjusts the tension on the blade. (Fig. 5.1)

Blade Tracking Adjustment Knob: Adjusts the blade tracking. (Fig. 5.1)

Blade Tension Quick Release: Quickly tensions or releases the blade without losing its setting. Only on the BP-310 and BP360. (Fig.5.2)

Guide Post Adjustment Knob: Raises and lowers the blade guide post. (Fig. 5.3)

Guide Post Locking Knob: Locks the blade guide post. (Fig. 5.3)

ON/OFF Switch: Starts and stops the blade motor. (Fig. 5.4)

ON/OFF Light Switch: Switches the work light on and off. (Fig. 5.4)

Mitre Gauge Lock Handle: Locks the mitre gauge at the current setting. (Fig. 5.5)

Fence Lock Lever: Locks the fence at its current position. (Fig. 5.5)

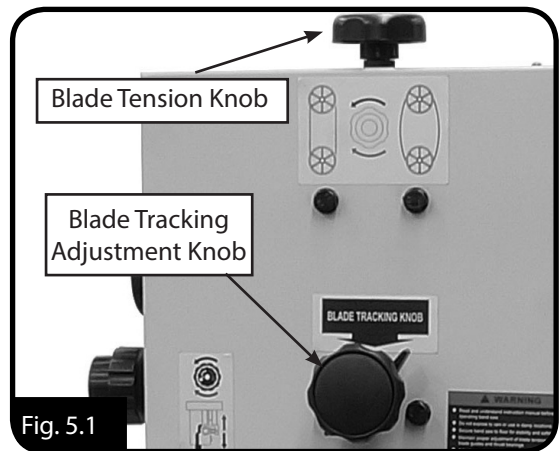

Fig. 5.1



Fig. 5.2

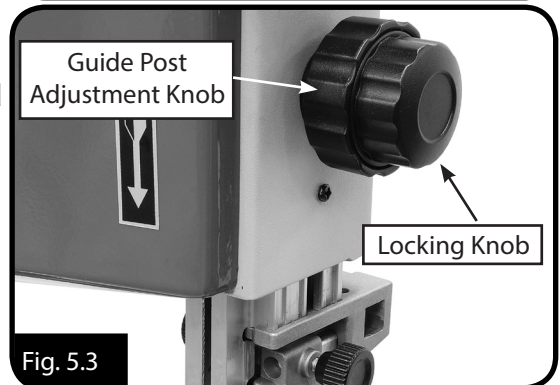

Fig. 5.3

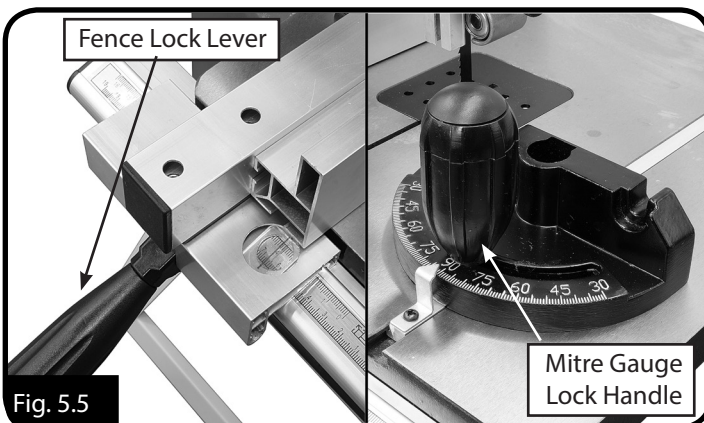

Fig. 5.5

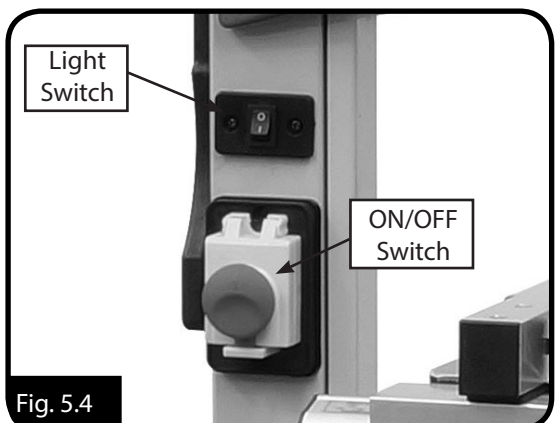

Fig. 5.4

5.2 BLADE INFORMATION

Selecting the right blade requires a knowledge of the various blade characteristics mentioned below, the type of material you plan to cut, and the type of cut you are going to perform.

Blade Length

The blade length is measured by the circumference. Blade lengths are usually unique to the brand of your band saw and the distance between wheels. The chart below displays the blade length for the model and available blades.

NOTE: "Available Blades" lists the stocked blades but other sizes and blade teeth are available from most local saw blade manufacturers

Model	Blade Length	Available Blades.
BP-225	1826mm	SKU: W950A SKU: W950B SKU: W950F
BP-310	2240mm	SKU: W420A SKU: W420B SKU: W420E
BP-360	2560mm	SKU: W955A SKU: W955B SKU: W955F

Blade Width

Measured from the back of the blade to the tip of the blade tooth (the widest point), blade width is often the first consideration given to blade selection. Blade width dictates the largest and smallest curve that can be cut, as well as how accurately it can cut a straight line.

Curve Cutting:

View the chart in Fig. 5.6 to determine the correct blade width for curve cutting. Determine the smallest radius curve that will be cut on the workpiece and use the corresponding blade width. (Fig. 5.6)

Straight Cutting:

Use the largest width blade available. (See specifications on Page 5 for the maximum width for the model)

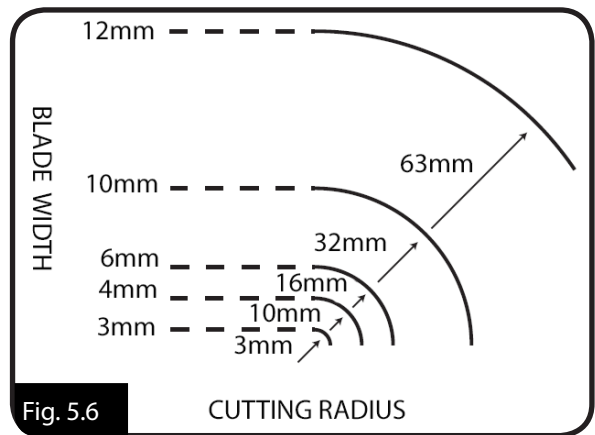

Fig. 5.6

CUTTING RADIUS

Tooth Style

When selecting blades, another option to consider is the shape, gullet size, teeth set and teeth angle—otherwise known as "Tooth Style." As shown Fig.5.7

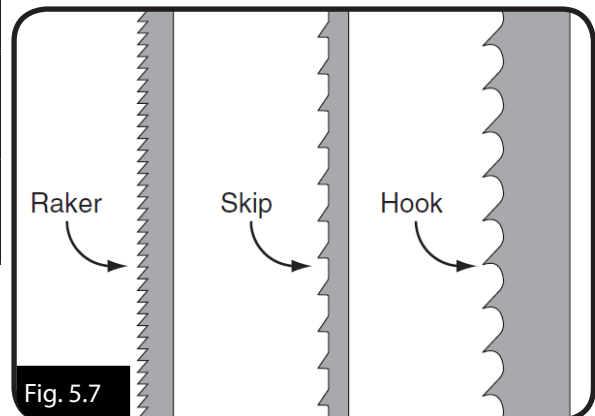

Fig. 5.7

Raker: Considered to be the standard because the tooth size and shape are the same as the tooth gullet.

Skip: This style is similar to a raker blade but is missing every other tooth. Skip toothed blades have a larger gullet, and cut faster.

Hook: This teeth type have a positive angle (downward) allows them to dig into the material. The gullets are usually rounded for easier waste removal. Excellent for the tough demands and ripping thick material.

5.3 CHANGING THE BLADE

To remove the blade:

1. DISCONNECT POWER FROM THE BAND SAW
2. Release the blade tension by turning the blade tension knob (BP-255 Fig. 5.8) or turn quick release lever to the left.(BP-310, BP-360 Fig. 5.9)
3. Remove the table insert and the table pin. Adjust the upper and lower guide bearings as far away as possible from the blade.
4. Open the upper and lower wheel covers, (Fig. 5.10)
Put on leather gloves and slide the blade off both wheels.
5. Rotate the blade 90° and slide it through the slot in the table.
6. Take the new blade and slide it through the table slot, ensuring that the teeth are pointing down toward the table.

NOTE: If the teeth will not point downward in any orientation, the blade is inside-out. Put on leather gloves, and remove the blade, and twist it right side-out.

7. Slip the blade through the guides, and mount it on the upper and lower wheels.
8. Tighten the blade tension quick release.
(BP-310, BP-360 only)
9. Apply tension to the blade by turning the tension control knob. Rotate the upper wheel slowly by hand as tension is applied to allow the blade to centre itself on the wheel. Adjust tracking if needed.
10. Adjust tension as described Page 16.
11. Adjust the upper/lower guide bearings and the support bearings.
12. Close the wheel covers.
13. Replace the table insert and table pin, (if fitted) being sure not to use excessive force when inserting the table pin.

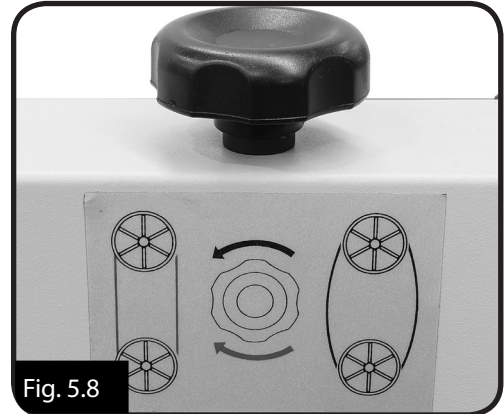

Fig. 5.8



Fig. 5.9



Fig. 5.10

CAUTION

All saw blades are dangerous and may cause personal injury. To reduce the risk of being injured, wear leather gloves when handling saw blades.

6. MAINTENANCE

Review the troubleshooting and procedures in this section to fix or adjust your machine if a problem develops. If you need replacement parts or you are unsure of your repair skills, then contact your local distributor or service provider. **NOTE:** Hafco/Woodmaster advise that extension leads should not be used permanently, but recommend that the plug be placed directly in to a wall socket.

6.1 TROUBLESHOOTING

Symptom	Possible Cause	Possible Solution
Machine does not start or a breaker trips.	<ol style="list-style-type: none"> 1. Plug/receptacle is at fault or wired incorrectly. 2. Motor connection wired incorrectly. 3. Power supply is at fault/switched OFF. 4. Motor ON/OFF switch is at fault. 5. Wiring is open/has high resistance. 6. Start capacitor is at fault. 7. Motor is at fault. 	<ol style="list-style-type: none"> 1. Test for good contact or correct the wiring. 2. Correct motor wiring connections 3. Have a qualified electrician check the voltage at the meter box, and that connections are not faulty. 4. Replace faulty ON/OFF switch. 5. Check for broken wires or corroded connections, and repair/replace as necessary. 6. Test/replace if faulty. 7. Repair/replace.
Machine stalls or is underpowered	<ol style="list-style-type: none"> 1. Wrong workpiece material (wood). 2. Processing speed too fast for task. 3. Low power supply voltage. 4. Run capacitor is at fault. 5. V-belt slipping. 6. Blade is slipping on wheels. 7. Motor bearings are at fault. 8. Motor has overheated. 9. Motor is at fault. 	<ol style="list-style-type: none"> 1. Use wood with correct moisture content, without glues, and little pitch/resins. 2. Decrease processing speed. 3. Ensure all hot lines have correct voltage on all phase. 4. Repair/replace. 5. Replace bad V-belt, align pulleys, and re-tension 6. Adjust blade tracking and tension. 7. Test by rotating shaft; rotational grinding/ loose shaft requires bearing replacement. 8. Clean off motor, let cool, and reduce workload. 9. Repair/replace.
Machine has vibration or noisy operation when running.	<ol style="list-style-type: none"> 1. Motor or component is loose. 2. V-belt worn or loose. 3. Motor fan is rubbing on fan cover. 4. Pulley is loose. 5. Machine is incorrectly mounted or sits unevenly on the floor. 6. Motor bearings are at fault. 7. Blade weld is at fault or teeth are broken. 8. Worn arbor bearings. 9. Wheels not aligned correctly. 10. Tyres incorrectly installed. 11. Bent or worn out blade. 12. Wheels out of balance. 	<ol style="list-style-type: none"> 1. Inspect/replace stripped or damaged bolts/nuts, and re-tighten with thread locking fluid. 2. Inspect/replace belt . 3. Replace dented fan cover 4. Realign/replace shaft, pulley, set screw, and key as required. 5. Adjust the feet on the bottom of the stand; relocate machine. 6. Test by rotating shaft and replace bearing if required 7. Replace blade 8. Check/replace arbor bearings. 9. Adjust wheel alignment (Page 22) 10. Re-install tyres. 11. Replace blade. 12. Replace wheels.

Symptom	Possible Cause	Possible Solution
Machine slows when operating	1. Applying too much pressure to workpiece. 2. Blade is dull.	1. Feed workpiece slower and in a smooth motion 2.. Replace blade
Ticking sound when the saw is running.	1. Blade weld contacting support bearing. 2. Blade weld may be failing	1. Use file or stone to smooth and round the back of the blade. 2. Inspect and replace blade if necessary
Blade touching table insert.	1. Excessive side pressure when cutting. 2. Table improperly adjusted	1. Reduce side pressure. 2. Adjust table
Vibration when cutting.	1. Loose or damaged blade.	1. Tighten or replace blade
Burn marks on the edge of the cut.	1. Too much side pressure when feeding workpiece. 2. Blade too wide for size of radius being cut	1. Feed workpiece straight into the blade. 2. Install a smaller width blade/increase blade tension.
Rough or poor quality cuts.	1. Blade lead.	1. Blade lead is commonly caused by too fast feed rate, a dull blade, or improper tension

6.2 WHEEL ALIGNMENT

Wheel alignment is one of the most important issues to ensure the best performance from your band saw. Over time vibration, and wandering blades cause tyre wear. This can be considerably reduced when the wheels are properly aligned. The procedure is as follows.

1. Remove the fence and table, then open both the wheel covers.
2. Make sure the guide blocks and rear support bearings have been moved away from the blade, then tighten your blade to the tension that it will be used during operation.
4. Place the straight edges against both wheels in the positions shown in Fig. 6.1
5. The hub on the bottom wheel allows you to adjust the lower wheel to be adjusted in the desired direction. Turning all the bolts clockwise in equal amounts pushes the wheel forward. Turning all the bolts counter clockwise moves the wheel towards the back of the machine. When the screws are used individually, each bolt controls the direction that the wheel tilts. (Fig. 6.2)

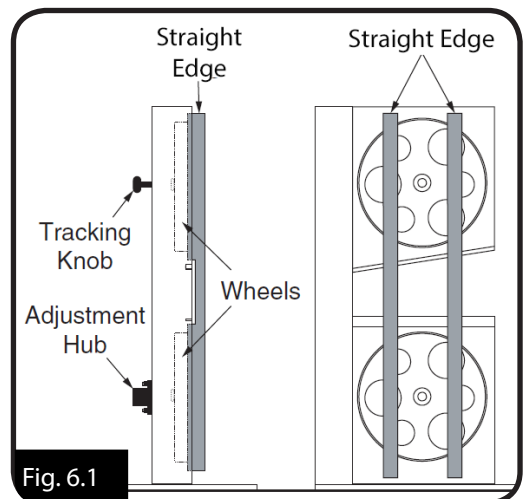

Fig. 6.1



Fig. 6.2

SPARE PARTS SECTION

The following section covers the spare parts diagrams and lists that were current at the time this manual was originally printed. Due to continuous improvements of the machine, changes may be made at any time without notification.

HOW TO ORDER SPARE PARTS

1. Have your machines **model number, serial number & date of manufacture** on hand, these can be found on the specification plate mounted on the machine
2. A scanned copy of your parts list/diagram with required spare part/s identified
3. Go to www.machineryhouse.com.au/contactus and fill out the enquiry form attaching a copy of scanned parts list.

CONTENTS

BP-255 Spare Parts.....	24
BP-255 Spare Parts List.....	25
BP-310, 360 Spare Parts.....	27
BP-310, 360 Spare Parts List.....	28

**SPARE PARTS
BP-255**

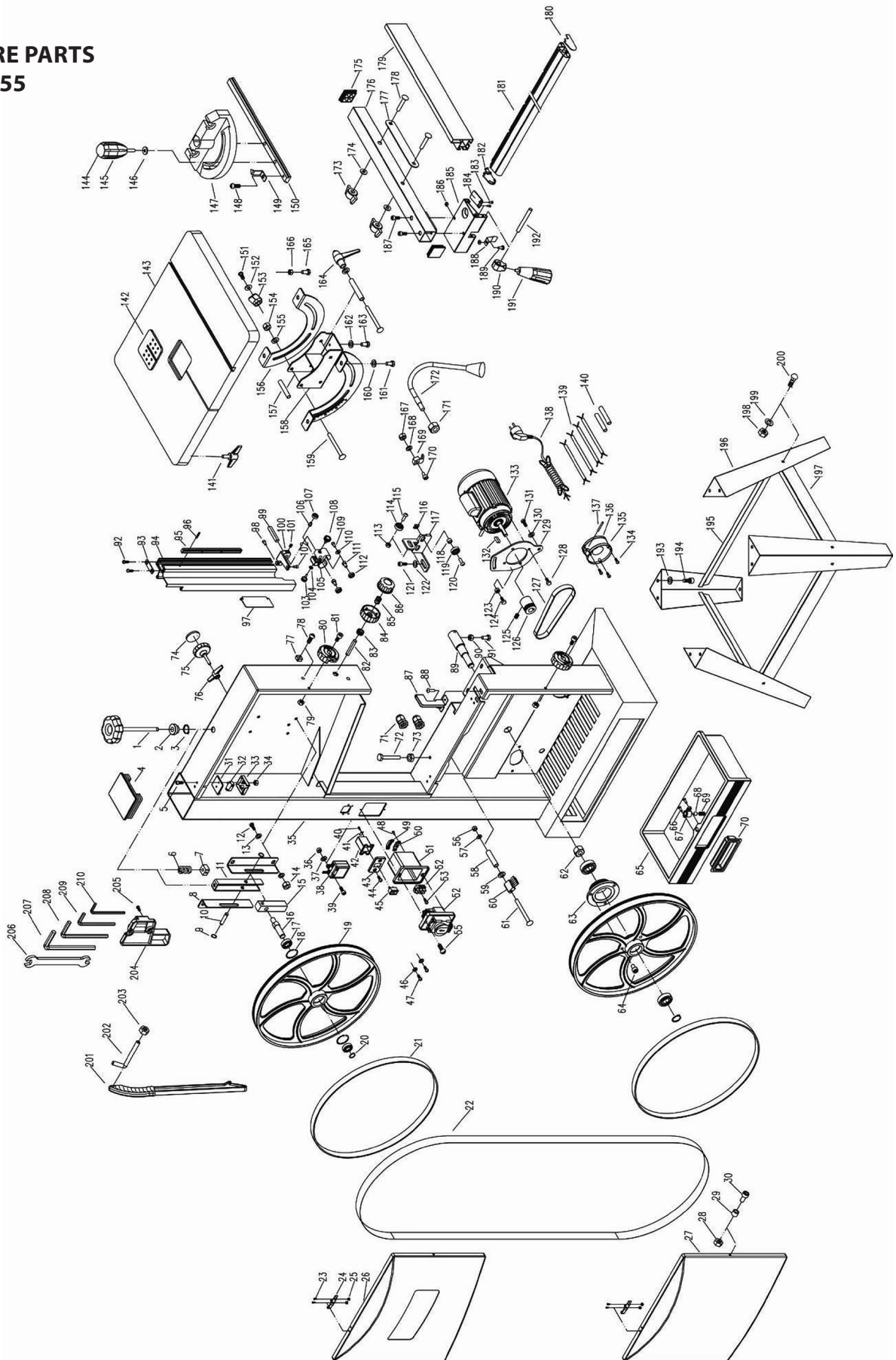

OPERATION MANUAL**BP-255 SPARE PARTS LIST**

No.	Description	Qty	No.	Description	Qty
1	Blade tension knob	1	51	Switch box	1
2	Bushing	1	52	Connecting terminal	1
3	Retaining ring	1	53	Thread forming screw	1
4	Frame cap	1	54	Main switch	1
5	Pan head screw	4	55	Pan head screw	2
6	Spring	1	56	Nut	1
7	Nut	1	57	Flat washer	1
8	Retaining ring	2	58	Bushing	1
9	Shaft	1	59	Flat washer	1
10	Guide plate	2	60	Brush	1
11	Pulling plate	1	61	Carriage bolt	1
12	Hex head bolt	4	62	Hex nut	1
13	Flat washer	8	63	Spindle pulley	1
14	Hex nut	4	64	Socket head bolt	3
15	bevel block	1	65	Dust drawer	1
16	Shaft	1	66	Thread forming screw	2
17	Ball bearing	4	67	Ball house	1
18	Retaining ring	4	68	Ball	1
19	Upper wheel	1	69	Spring	1
20	Retaining ring	2	70	Drawer handle	1
21	Tyre	2	71	Cord bushing	2
22	Blade	1	72	Limiting shaft	1
23	Pan head screw	4	73	Hex nut	1
24*	Interlock switch key	2	74	Knob cap	1
25*	Hex nut	4	75	Tracking set knob	1
26	Upper cover	1	76	Tracking lock knob	1
27	Lower cover	1	77	Guide block	2
28	Lock nut	2	78	Pan head screw	2
29	Bushing	2	79	Lock nut	2
30	Socket head bolt	2	80	Cover lock knob	2
31*	Cover	2	81	Socket head bolt	2
32*	Interlock switch	2	82	Shaft	1
33*	Switch	2	83	Gear	1
34*	Hex nut	4	84	Upper guide adjusting knob	1
35	Frame	1	85	Spring	1
36	Nut	1	86	Lock knob	1
37	Flat washer	1	87	Lower guard	1
38	LED driver	1	88	Socket head bolt	2
39	Socket head bolt	1	89	Shaft	1
40	Thread forming screw	1	90	Hex nut	4
41	Cord clamp	1	91	Hex head bolt	4
42	Led switch box	1	92	Thread forming screw	2
43	Switch cover	1	93	Limiting plate	1
44	Pan head screw	2	94	Upper blade guard	1
45	LED switch	1	95	Rack	1
46	Serrated washer	2	96	Pin	2
47	Pan head screw	2	97	Sliding cover	1
48	Thread forming screw	4	98	Socket head bolt	1
49	Cord clamp	1	99	Connecting shaft	1
50	Cord clamp	1	100	Support block	1

BP-255 SPARE PARTS LIST

No.	Description	Qty	No.	Description	Qty
101	Set screw	1	151	Pan head screw	1
102	Thread forming screw	1	152	Flat washer	1
103	Knob	1	153	Pointer	1
104	Flat washer	1	154	Lock nut	1
105	Bearing cover	1	155	Flat washer	2
106	Shaft	1	156	Angle guide plate	2
107	Ball bearing	1	157	Bushing	2
108	Knob	1	158	Table beveling base	1
109	Socket head bolt	2	159	Carriage blot	2
110	Flat washer	2	160	Flat washer	4
111	Shaft	2	161	Hex head bolt	4
112	Ball bearing	2	162	Flat washer	4
113	Hex nut	1	163	Hex head bolt	4
114	Ball bearing	1	164	Lock handle	1
115	Socket head bolt	1	165	Hex head bolt	1
116	Nut	2	166	Hex nut	1
117	Lower guide plate	1	167	Nut	1
118	Bushing	2	168	Flat washer	1
119	Ball bearing	2	169	Cord clamber	1
120	Socket head bolt	2	170	Socket head bolt	1
121	Socket head bolt	2	171	Hex nut	1
122	Flat washer	2	172	LED light	1
123	Hex nut	2	173	Knob	2
124	Socket head bolt	2	174	Flat washer	2
125	Set screw	1	175	Fence support cap	2
126	Motor pulley	1	176	Fence support	1
127	Belt	1	177	Guide plate	1
128	Hex head bolt	4	178	Carriage blot	2
129	Motor support plate	1	179	Fence	1
130	Flat washer	2	180	Guide rail cap	1
131	Socket head bolt	2	181	Guide rail	1
132	Key	1	182	Guide rail cap	1
133	Motor	1	183	Thread forming screw	2
134	Thread forming screw	3	184	Pointer	1
135	Dust port	1	185	Sliding base	1
136	Dust port cover	1	186	Nut	3
137	Pin	1	187	Socket head bolt	1
138	Power cord	1	188	Spring plate	1
139	Inner cord	4	189	Pan head screw	1
140	Flexible tube	2	190	Lock block	1
141	Guide rail lock knob	4	191	Lock handle	1
142	Table insert	1	192	Shaft	1
143	Table	1	193	Flat washer	8
144	Cap	1	194	Socket head bolt	8
145	Handle	1	195	Long brace	2
146	Washer	1	196	Leg	4
147	Miter gauge	1	197	Short brace	2
148	Pan head screw	1	198	Hex nut	8
149	Pointer	1	199	Flat washer	8
150	Rod	1	200	Carriage blot	8

BP-255 SPARE PARTS LIST

No.	Description	Qty
201	Push stick	1
202	Hook	1
203	Hex nut	1
204	Rack	1
205	Pan head screw	2
206	Open spanner	1
207	6mm hex wrench	1
208	5mm hex wrench	1
209	4mm hex wrench	1
210	3mm hex wrench	1

**SPARE PARTS
BP-310 & BP-360**

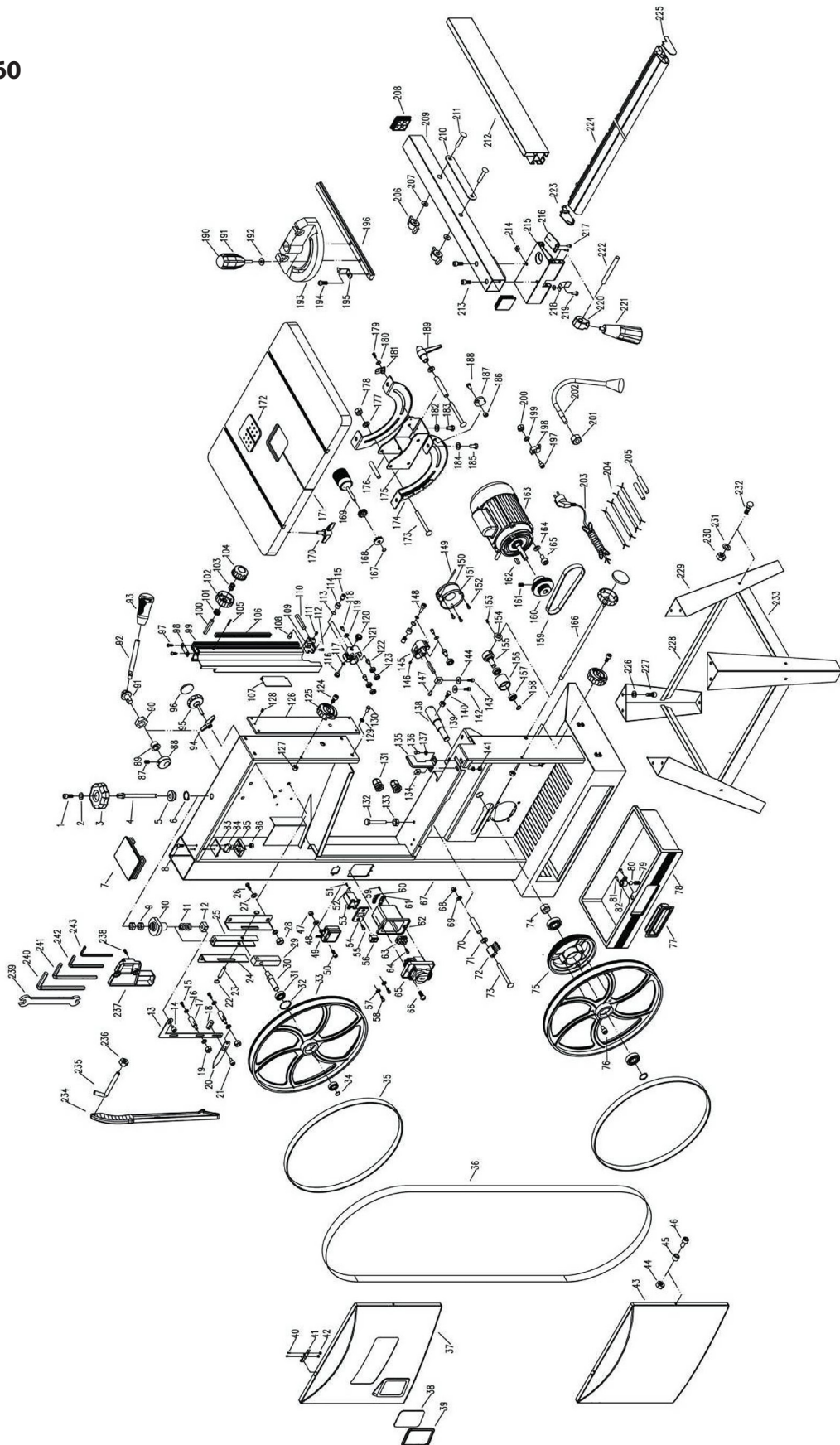

OPERATION MANUAL

BP-310 & BP-360 SPARE PARTS LIST

No.	Description	Qty	No.	Description	Qty
1	Socket head screw	1	51	Thread forming screw	1
2	Flat washer	1	52	Cord clamp	1
3	Blade tension knob	1	53	Led switch box	1
4	Screw	1	54	Switch cover	1
5	Bushing	1	55	Pan head screw	2
6	Retaining ring	1	56	LED switch	1
7	Frame cap	1	57	Serrated washer	2
8*	Pan head screw	4	58	Pan head screw	2
9	Hex nut	2	59	Thread forming screw	4
10	Tension bracket	1	60	Cord clamp	1
11	Spring	1	61	Cord clamp	1
12	Nut	1	62	Switch box	1
13	Connecting plate	1	63	Connecting terminal	1
14	Bolt	1	64	Thread forming screw	1
15	Hex head bolt	3	65	Main switch	1
16	Flat washer	6	66	Pan head screw	2
17	Guide rod	3	67	Frame	1
18	Nut	1	68	Nut	1
19	Lock nut	3	69	Flat washer	1
20	Blade tension pointer	1	70	Bushing	1
21	Bolt	1	71	Flat washer	1
22	Retaining ring	2	72	Brush	1
23	Shaft	1	73	Carriage blot	1
24	Guide plate	2	74	Hex nut	1
25	Pulling plate	1	75	Spindle pulley	1
26	Hex head bolt	4	76	Socket head screw	3
27	Flat washer	8	77	Drawer handle	1
28	Hex nut	4	78	Dust drawer	1
29	bevel block	1	79	Spring	1
30	Shaft	1	80	Ball	1
31	Ball bearing	4	81	Thread forming screw	2
32	Retaining ring	4	82	Ball house	1
33	Upper wheel	2	83*	Cover	2
34	Retaining ring	2	84*	Interlock switch	2
35	Tyre	2	85*	Switch	2
36	Blade	1	86*	Hex nut	4
37	Upper cover	1	87	Set screw	1
38	Viewing window	1	88	Cam	1
39	Window case	1	89	Bushing	1
40*	Pan head screw	4	90	Nut	1
41*	Interlock switch key	2	91	Shaft	1
42*	Hex nut	4	92	Handle	1
43	Lower cover	1	93	Handle cap	1
44	Lock nut	2	94	Tracking set knob	1
45	Bushing	2	95	Tracking lock knob	1
46	Socket head screw	2	96	Cap	2
47	Nut	1	97	Thread forming screw	2
48	Flat washer	1	98	Limiting plate	1
49	LED driver	1	99	Upper blade guard	1
50	Socket head screw	1	100	Shaft	1

OPERATION MANUAL**BP-310 & BP-360 SPARE PARTS LIST**

No.	Description	Qty	No.	Description	Qty
101	Gear	1	151	Dust port	1
102	Upper guide adjusting knob	1	152	Pan head screw	3
103	Spring	1	153	Set screw	1
104	Lock knob	1	154	Bushing	1
105	Rack	1	155	Idle pulley shaft	1
106	Pin	2	156	Idle pulley	1
107	Sliding cover	1	157	Ball bearing	2
108	Socket head bolt	1	158	Retaining ring	1
109	Support block	1	159	Belt	1
110	Connecting shaft	2	160	Motor pulley	1
111	Set screw	1	161	Set screw	1
112	Thread forming screw	2	162	Key	1
113	Retaining ring	2	163	Motor	1
114	Bearing	2	164	Flat washer	4
115	Shaft	2	165	Socket head screw	4
116	Knob	1	166	Belt tension knob	1
117	Flat washer	1	167	Retaining ring	1
118	Socket head screw	2	168	Gear	2
119	Flat washer	2	169	Table adjusting knob	1
120	Knob	1	170	Lock knob	4
121	Guide block	1	171	Table	1
122	Shaft	4	172	Table insert	1
123	Ball bearing	8	173	Carriage bolt	2
124	Socket head screw	2	174	Angle guide plate	2
125	Cover lock knob	2	175	Table beveling base	1
126	Guide plate	1	176	Bushing	2
127	Lock nut	2	177	Flat washer	2
128	Set screw	1	178	Lock nut	1
129	Flat washer	4	179	Pan head screw	1
130	Hex head bolt	4	180	Flat washer	1
131	Cord bushing	2	181	Pointer	1
132	Limiting shaft	1	182	Flat washer	4
133	Hex nut	1	183	Hex head bolt	4
134	Guide block	1	184	Flat washer	4
135	Lower guard	1	185	Socket head screw	4
136	Hex head bolt	1	186	Hex nut	4
137	Flat washer	2	187	Limiting plate	1
138	Shaft	1	188	Hex head bolt	1
139	Hex nut	4	189	Locking handle	1
140	Hex head bolt	4	190	Cap	1
141	Hex nut	1	191	Handle	1
142	Hex head bolt	1	192	Washer	1
143	Hex head bolt	1	193	Miter gauge	1
144	Flat washer	2	194	Pan head screw	1
145	Guide block	1	195	Pointer	1
146	Set screw	1	196	Rod	1
147	Socket head screw	1	197	Socket head screw	1
148	Socket head screw	1	198	Cord clamp	1
149	Pin	1	199	Flat washer	1
150	Dust port cover	1	200	Nut	1

OPERATION MANUAL**BP-310 & BP-360 SPARE PARTS LIST**

No.	Description	Qty	No.	Description	Qty
201	Hex nut	2	235	Hook	1
202	LED driver	1	236	Hex nut	1
203	Power cord	1	237	Rack	1
204	Inner cord	4	238	Pan head screw	2
205	Flexible tube	2	239	Open spanner	1
206	Knob	2	240	6mm hex wrench	1
207	Flat washer	2	241	5mm hex wrench	1
208	Fence support cap	2	242	4mm hex wrench	1
209	Fence support	1	243	3mm hex wrench	1
210	Guide plate	1			
211	Carriage blot	2			
212	Fence	1			
213	Socket head bolt	2			
214	Nut	3			
215	Sliding base	1			
216	Pointer	1			
217	Thread forming screw	2			
218	Spring plate	1			
219	Pan head screw	1			
220	Lock block	1			
221	Lock handle	1			
222	Shaft	1			
223	Guide rail cap	1			
224	Guide rail	1			
225	Guide rail cap	1			
226	Flat washer	8			
227	Socket head screw	8			
228	Long brace	2			
229	Leg	4			
230	Hex nut	8			
231	Flat washer	8			
232	Carriage blot	8			
233	Short brace	2			
234	Push stick	1			

WARNING

General Machinery Safety Instructions

Machinery House
requires you to read this entire Manual before using this machine.

- 1. Read the entire Manual before starting machinery.** Machinery may cause serious injury if not correctly used.
- 2. Always use correct hearing protection when operating machinery.** Machinery noise may cause permanent hearing damage.
- 3. Machinery must never be used when tired, or under the influence of drugs or alcohol.** When running machinery you must be alert at all times.
- 4. Wear correct Clothing.** At all times remove all loose clothing, necklaces, rings, jewelry, etc. Long hair must be contained in a hair net. Non-slip protective footwear must be worn.
- 5. Always wear correct respirators around fumes or dust when operating machinery.** Machinery fumes & dust can cause serious respiratory illness. Dust extractors must be used where applicable.
- 6. Always wear correct safety glasses.** When machining you must use the correct eye protection to prevent injuring your eyes.
- 7. Keep work clean and make sure you have good lighting.** Cluttered and dark shadows may cause accidents.
- 8. Personnel must be properly trained or well supervised when operating machinery.** Make sure you have clear and safe understanding of the machine you are operating.
- 9. Keep children and visitors away.** Make sure children and visitors are at a safe distance for you work area.
- 10. Keep your workshop childproof.** Use padlocks, Turn off master power switches and remove start switch keys.
- 11. Never leave machine unattended.** Turn power off and wait till machine has come to a complete stop before leaving the machine unattended.
- 12. Make a safe working environment.** Do not use machine in a damp, wet area, or where flammable or noxious fumes may exist.
- 13. Disconnect main power before service machine.** Make sure power switch is in the off position before re-connecting.
- 14. Use correct amperage extension cords.** Undersized extension cords overheat and lose power. Replace extension cords if they become damaged.
- 15. Keep machine well maintained.** Keep blades sharp and clean for best and safest performance. Follow instructions when lubricating and changing accessories.
- 16. Keep machine well guarded.** Make sure guards on machine are in place and are all working correctly.
- 17. Do not overreach.** Keep proper footing and balance at all times.
- 18. Secure workpiece.** Use clamps or a vice to hold the workpiece where practical. Keeping the workpiece secure will free up your hand to operate the machine and will protect hand from injury.
- 19. Check machine over before operating.** Check machine for damaged parts, loose bolts, Keys and wrenches left on machine and any other conditions that may effect the machines operation. Repair and replace damaged parts.
- 20. Use recommended accessories.** Refer to instruction manual or ask correct service officer when using accessories. The use of improper accessories may cause the risk of injury.
- 21. Do not force machinery.** Work at the speed and capacity at which the machine or accessory was designed.
- 22. Use correct lifting practice.** Always use the correct lifting methods when using machinery. Incorrect lifting methods can cause serious injury.
- 23. Lock mobile bases.** Make sure any mobile bases are locked before using machine.
- 24. Allergic reactions.** Certain metal shavings and cutting fluids may cause an allergic reaction in people and animals, especially when cutting as the fumes can be inhaled. Make sure you know what type of metal and cutting fluid you will be exposed to and how to avoid contamination.
- 25. Call for help.** If at any time you experience difficulties, stop the machine and call you nearest branch service department for help.

WARNING

Wood Bandsaw Safety Instructions

Machinery House
requires you to read this entire Manual before using this machine.

- 1. Maintenance.** Make sure the bandsaw is turned off and disconnect from the main power supply and make sure all moving parts have come to a complete stop before any inspection, adjustment or maintenance is carried out.
- 2. Bandsaw Condition.** Bandsaw must be maintained for a proper working condition. Never operate a bandsaw that has damaged or worn parts. Scheduled routine maintenance should be performed on a scheduled basis.
- 3. Blade Condition.** Never operate a bandsaw with a dull, cracked or badly worn blade. Before using a bandsaw inspect blades for missing teeth and cracks. Replace if required.
- 4. Replacing Blade.** Make sure teeth are face forward to the workpiece and blade is properly tensioned. Wear gloves to protect hands and wear safety glasses to protect your eyes.
- 5. Use Correct Blade.** Use the correct blade for the material being cut and the type of cut you are performing.
- 6. Hand Hazard.** Keep hands and fingers clear from the line of cut of the blade. Serious injury can occur.
- 7. Leaving a bandsaw Unattended.** Always turn the bandsaw off and make sure all moving parts have come to a complete stop before leaving the bandsaw. Do not leave bandsaw running unattended for any reason.
- 8. Avoiding Entanglement.** Blade guard must be used at all times. Remove loose clothing, belts, or jewelry items. Never wear gloves while machine is in operation. Tie up long hair and use the correct hair nets to avoid any entanglement with the bandsaw moving parts.
- 9. Understand the machines controls.** Make sure you understand the use and operation of all controls.
- 10. Power outage.** In the event of a power failure during use of the bandsaw, turn off all switches to avoid possible sudden start up once power is restored.
- 11. Work area hazards.** Keep the area around the bandsaw clean from oil, tools, chips. Pay attention to other persons in the area and know what is going on around the area to ensure unintended accidents.
- 12. Workpiece Handling.** Never hold small workpieces with your fingers during a cut. Always support/feed the workpiece with push stick, table support, vice, or some sort of clamping fixture.
- 13. Hearing protection and hazards.** Always wear hearing protection as noise generated from bandsaw blade and workpiece vibration, material handling can cause permanent hearing loss over time.
- 14. Cutting techniques.** Plan your cuts so you always cut out of the wood. Do not back the workpiece away from the blade while the saw is running. If you need to back the workpiece out, turn off the bandsaw and wait till the blade has come to a complete stop, and do not twist or put excessive stress on the blade while backing work out.
- 15. Feeding material.** Always feed material evenly and smoothly. Do not force or twist blade while cutting, especially while cutting small radii material.
- 16. Job Material.** This machine is designed to cut wood only. It is not designed to cut metal or use cutting fluid. Always inspect your material before cutting. If you have any doubt about stability or structural integrity of your stock do not cut.
- 17. Starting position/speed.** Never turn the bandsaw on when the blade is resting on the workpiece. Allow blade to reach full speed before cutting.
- 18. Guards.** Do not operate bandsaw without the blade guard in place or with the doors open. Ensure all guards removed to do maintenance or change blades on the machine are refitted correctly in place before the machine is used again.
- 19. Stopping the Blade.** Do not stop or slow the blade with your hand or workpiece. Allow the blade to stop on its own, unless the machine is equipped with a brake.
- 20. Call for help.** If at any time you experience difficulties, stop the machine and call your nearest branch service department for help.

PLANT SAFETY PROGRAM

NEW MACHINERY HAZARD IDENTIFICATION, ASSESSMENT & CONTROL

Wood Bandsaw

Developed in Co-operation Between A.W.I.S.A and Australia Chamber of Manufactures
This program is based upon the Safe Work Australia, Code of Practice - Managing Risks of Plant in the Workplace (WHSA 2011 No10)

Item No.	Hazard Identification	Hazard Assessment	Risk Control Strategies <small>(Recommended for Purchase / Buyer / User)</small>
A	ENTANGLEMENT	HIGH	Eliminate, avoid loose clothing / Long hair etc.
B	CRUSHING	LOW	Ensure bandsaw is on level ground to and safe place to prevent it falling.
C	CUTTING, STABBING, PUNCTURING	MEDIUM	Blade guards should always be in the closed position before starting machine. Top blade guide system should be adjusted to suit material thickness. Isolate main power switch before changing blade, cleaning or adjusting. Use a push stick to remove off-cuts. Hands must always be kept well away from blade at all times. Check blade tracking before starting.
D	SHEARING	MEDIUM	Make sure all guards are secured shut when machine is on.
F	STRIKING	LOW	Support long heavy work pieces. Remove all loose objects around moving parts. Wear safety glasses
H	ELECTRICAL	MEDIUM	Should blade break turn off machine immediately and use foot brake to stop if supplied. All electrical enclosures should only be opened with a tool that is not to be kept with the machine.
O	OTHER HAZARDS, NOISE, DUST.	LOW	Wear hearing protection as required. Must be connected to dust extraction.
Plant Safety Program to be read in conjunction with manufactures instructions			



www.machineryhouse.com.au



www.machineryhouse.co.nz

Authorised and signed by:
Safety officer:

.....
Manager:

.....

Revised Date: 12th March 2012